



Thank you for your purchasing. Before you use the product, please read the instruction manual carefully and save for further reference.

Manufacturer: Shanghai Xiaoyi Technology Co., Ltd.
Address: 6F, Building E, No.2889, Jinke Road, Shanghai, China.
Tel: +86-21-6165 6722
<http://www.yitechnology.com>
V 1.1

YI-M1 Mirrorless Digital Camera User Manual

Specification

Product Type		Video	
Model	Y1-M1	Video Resolutions	4K 3840 × 2160 30fps, 2K 2048 × 1536 30fps, FULL HD 1920 × 1080 60fps, 30fps, 24fps, HD 1280 × 720 60fps, 30fps, 24fps, VGA 640 × 480 240fps
Camera Type	Interchangeable-lens digital camera		
Lens Mount	Micro four thirds		
Equivalent Focal Length	Approximately 2x focal length		
Number of Pixels (effective)/ aspect ratio	Number of pixels(effective): 20.16 megapixels Number of pixels(total): 21.77 megapixels Image sensor aspect ratio: 1.33 (4:3)	Video Format	MPEG-4H.264
Sensor Size	17.3mm × 13mm		Audio Format
Image Quality		Microphone	Stereo
Maximal Resolution:	20M: 5184 × 3888 pixel	Speaker	Mono
Image Quality:	50M, 20M, 16M, 8M, 3M, VGA	Record/Delete	
File Format	RAW, JPEG (compression: Super Fine 1/2.7, Fine1/4, Normal 1/8, Exif v2.3)	Storage Type	SD/SDHC/SDXC (max 512G)
Focus		Memory Card Settings	Erase all, Format
Focus System	Contrast detect	Connectivity	
Autofocus	Face detection	USB	USB 2.0
	Single-AF	HDMI	Yes (Micro HDMI)
	Continuous AF	Wireless	Yes (2.4G)
Manual Focus	LCD touch and shoot AF	BLE	Yes (4.1)
	Yes (Peak MF and Magnifier MF)	Remote Control	Remote Control: currently not supported (coming soon via App update)
Focus Brightness Range	-4EV~20EV	Playback Modes	
Number of Focus Points	81 points	Playback Modes	Mode: Still Image: Single, Single with Detail Info, Index Display, Magnification Video: Play, F/W, B/K, Pause
LCD Screen			Playback modes: Picture - Single, Single with Detail Info, Index, Enlarged Video - Play, Forward, Backward, Pause
Screen size	3" 1.04 MP (approx.)		Picture Edit
Resolution	720RGB × 480	Others	
Touch Screen	Yes	Battery	Lithium, up to 380 shoots (Based on the new and fast AF Firmware, adopts CIPA standard testing criteria.)
Brightness Adjustment	Yes	Dimensions	113.5mm(W) × 64.3mm(H) × 33.6mm (D) (Protrusions excluded)
Exposure		Timelapse Recording	Yes (automatically create timelapse video)
Mechanical Shutter Speed	1/4000s~60s	Aspect Ratios	4:3, 3:2, 16:9, 1:1
Exposure Modes	Auto, Program, Aperture-Priority, Shutter-Priority, Manual Shutter (B mode, T mode) Scanning Panorama, Scenery Mode, Master Guide	Panorama Mode	Yes
		Firmware Update	
Metering Modes	Multi-segment Metering Mode, Spot Metering Mode, Center-weighted Metering Mode	Firmware Update	Camera: via smartphone or PC; Lens: along with camera upgrade
ISO	Auto, 100, 200, 400, 800, 1600, 3200, 6400, 12800, 25600	Working Condition	
Scene Modes	Portrait, Landscape, Sport, Night scene, Candle, Sunset, Fireworks, Beach & Snow	Operating	14~104 F°, 30~90% RH
Exposure Compensation	±5EV	Storage	-4~140 F, 10~90% RH
Exposure Bracketing	Yes		
HDR	Yes		
Flash			
External Flash	Yes		
Flash Modes	Auto, On, Off,		
Flash Sync Speed	1/125s		
Driver modes			
Driver Modes	Single, Continuous, Timer (2s, 10s)		
Continuous Speed	5fps		
Color			
Color Modes	Standard, Portrait, Wide B&W, High-contrast B&W		
White Balance	Auto, Sunny, Shadow, Cloudy, Incandescent, CWB (2000~11500)		
WB Bracketing	Yes		
Color Space	sRGB, AdobeRGB		

Contents

1. Contents of Package	1
2. Parts of the Camera	2
3. Getting Started	4
1). Insert the battery	
2). Insert the memory card	
3). Place/remove the lens	
4). Charge the battery	
5). Attach the strap	
4. Powering the camera on and off	7
5. Setting the Date and Time	8
6. Select shooting mode	9
7. Shoot Pictures / Record Videos	10
1). Shoot pictures	
2). Record videos	
8. Image/Video Playback	12
1). View/edit still pictures	
2). Detailed info/index display	
3). Enlarged view	
4). Delete pictures	
5). Watch videos	
9. Connect YI Mirrorless App to YI-M1 Mirrorless Digital Camera	15
10. Safety precautions	17
11. Wireless functions	18

1. Contents of Package

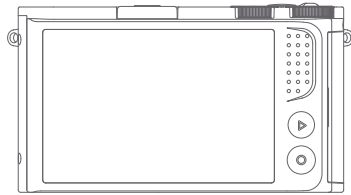

Camera body × 1



Body cap × 1
(attached)

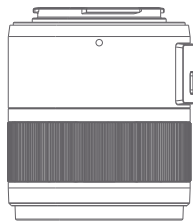

Lens × 1
(Varies on kit, quantity of lens may vary)



Lens cap × 1



Strap × 1

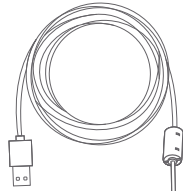

USB cable × 1

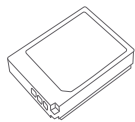

Battery × 1

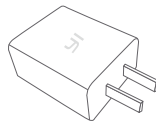

Power Adapter × 1



User Manual × 1

2. Parts of the Camera

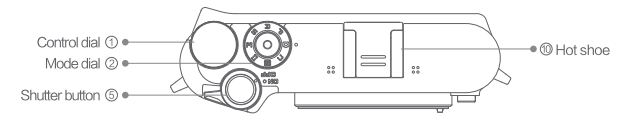
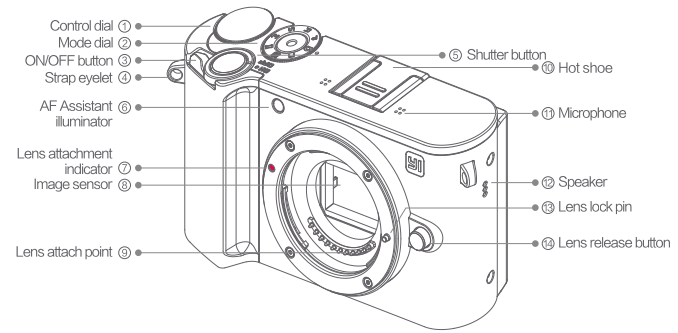

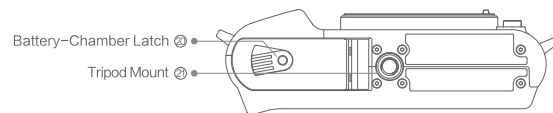
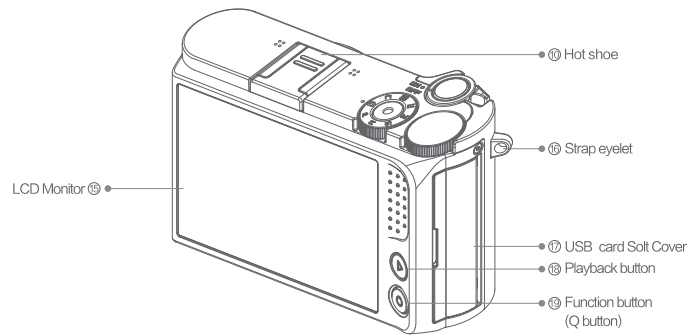

3. Getting Started

1. Inserting the Battery

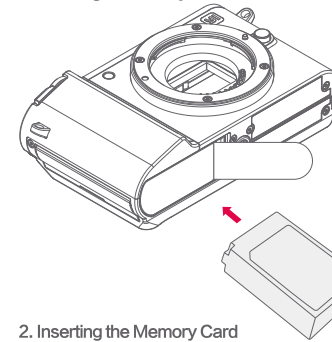

Gently slide the battery-chamber latch to open. Insert the battery contacts first in the direction shown by the arrow. Close the cover and latch the chamber.

2. Inserting the Memory Card

Turn the camera off and open the memory card slot cover. Align the memory card with the label to LCD monitor, then slide it in until it clicks into place at the back of the slot. To remove: press the card in until it unlocks and release it slowly.

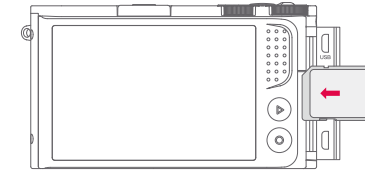

3. Attaching / Removing the lens

1) Attaching the lens
Align the lens attachment indicator (red) on the body with the alignment indicator (red) on the lens, then insert the lens into the camera's body.
Rotate the lens clockwise until you hear it click (direction indicated by arrow).

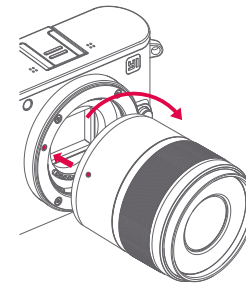

- 2) Removing the lens
Press the lens release button while rotating the lens in the direction of the arrow.

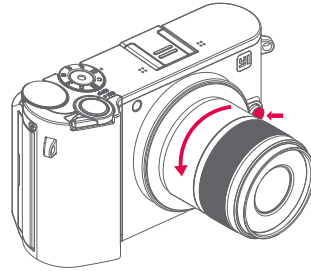

4. Charging the Battery

You can use the USB cable to charge via adapter or PC. 5V/1A power adapter is recommended.

Charging via USB: takes about 3 hours for complete charge.
Charging with charger accessory: takes about 2.5 hours for complete charge.
Charging time depends on battery lifetime and environment conditions.
Also if the battery has not been used for a long time, it takes longer to charge.

NOTE: If nothing appears on the LCD monitor after connecting the camera to a computer, the battery may be out of power. Please keep the camera connected to the computer until the battery has charged, then disconnect and connect the camera again.

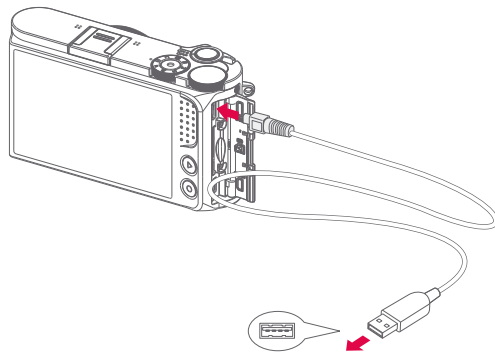

5. Attaching the strap

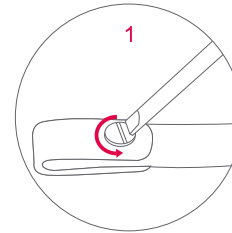

Untighten the screw

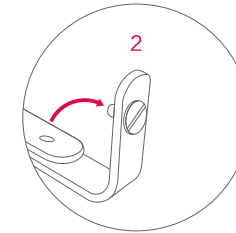

Insert one side of the strap go through the eyelet.

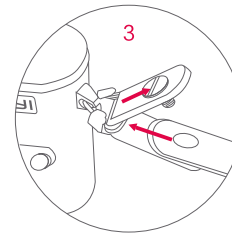

Tighten the screw to secure the strap and leather pad

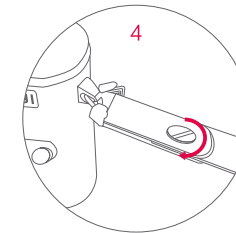

Once the screw is tightened and the strap is placed, repeat the same steps with the other side of the strap.

4. Powering the camera on and off

1. Powering on

Turn On/Off dial Clockwise.

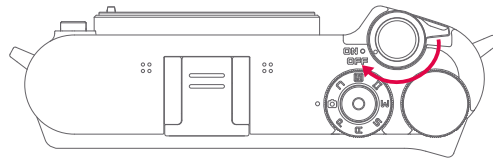

2. Powering off

Turn On/Off dial counter-clockwise.

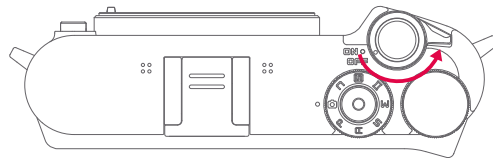

5. Setting the Date and Time

Menu display

[Basic settings] [Date and time]

- Swipe right on the LCD monitor

- Select [Basic settings]

- Find [Basic settings]

- Select [Date and time] sub-menu

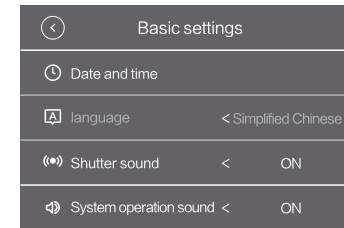

Slide the screen up or down to adjust options.

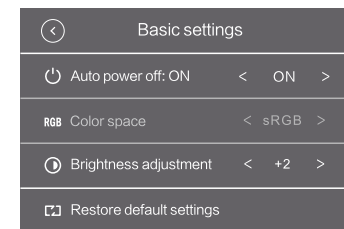
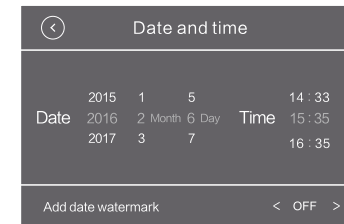

- You can adjust color space, screen brightness, or restore to default settings by configuring settings under [Basic settings] menu.
- Tap "Back" button on the upper-left hand corner of the LCD Monitor or half push the shutter to go back to Live View screen.
- You can also press the Q button to return to Live View screen.

6. Select shooting mode

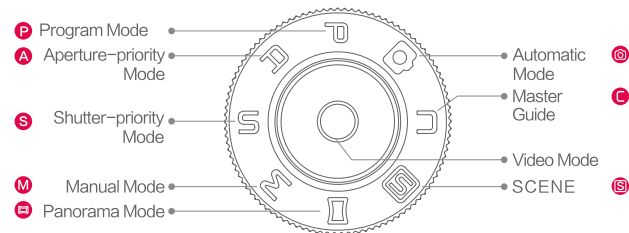

Automatic Mode	A fully automated mode in which the camera automatically configures the best setting for the current scene. All you need to do is to push the shutter button.
Aperture-priority Mode	Select the aperture to control the depth of field, and let the camera automatically adjust to the appropriate shutter speed.
Shutter-priority Mode	Select the shutter speed in order to have different moving effects or to make sure the clarity of the image.
Manual Mode	Set the aperture, shutter speed, ISO and other shooting parameters in order to have the free exposure control.
Panorama Mode	Shoot with wide-angle images using this mode.
Video	Record videos.
Master Guide	Download composition templates from YI Mirrorless App to create high-quality images just as you are having a master by your side
SCENE	Select a scene that goes well with the current shooting environment to achieve professional level results.
Program Mode	Camera automatically sets the optimum aperture and shutter speed for best results.

7. Shoot Pictures / Record Videos

1. Shooting still pictures

- 1) Select a shooting mode.
- 2) Set up the camera and decide on the composition.
- 3) Adjust the focus and make sure the subject is clear:
 - Focus on the subject by touching the subject on the LCD monitor.
 - Tap Q button in Live View screen to change focus modes.
 - Press the shutter button halfway and a green frame (AF target) will be displayed in the focus location.

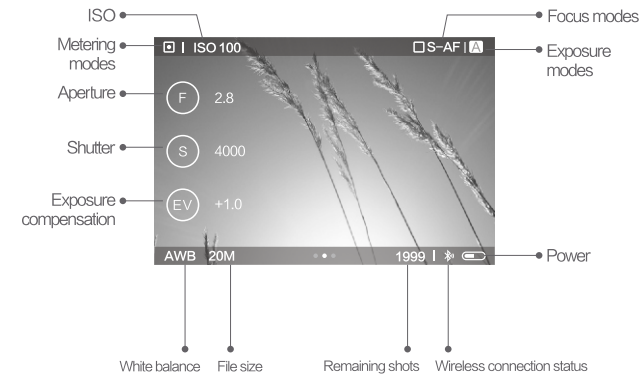

- Aperture: Rotate the control dial set the aperture in mode A.
 - Shutter: Rotate the control dial to select shutter speed in mode S.
 - Exposure compensation: Press the exposure compensation button, then rotate the control dial to set the compensation value.
- 4) Press the shutter button all the way down to take a picture.
 - When the LCD Monitor enabled, tap directly on the subject in the Live View screen to focus and shoot.
 - After shooting, the image will be displayed on the LCD Monitor. (display time is depends on the time you set in [Auto Playback])

2. Record videos

- 1) During the display of Live View screen, select the video button on the mode dial to record video.
 - Set the parameters to your preference with [Video Setting] in advanced.

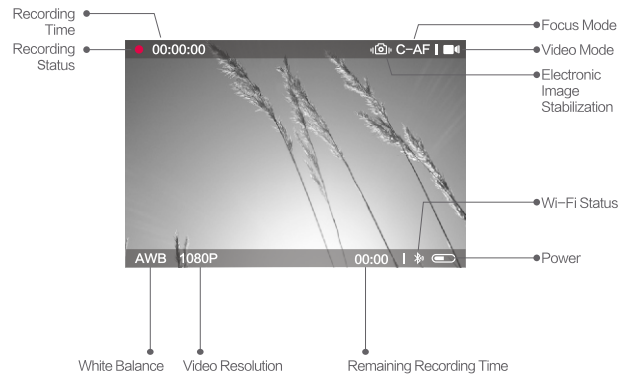
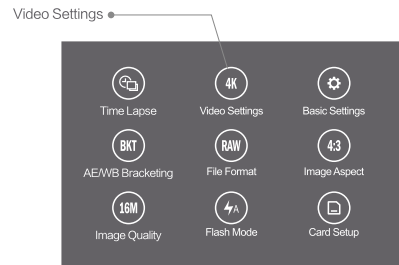

- 2) Press the  button again to end recording.

8. Image/Video Playback

1. View/edit still pictures

- 1) Press the  button to view/edit pictures/videos.
 - The last captured image/video will be displayed.
 - Slide the screen left or right to switch in between pictures and videos.
 - Long press (about 0.5s) image to enter editing interface. Tap again to exit single viewing mode.

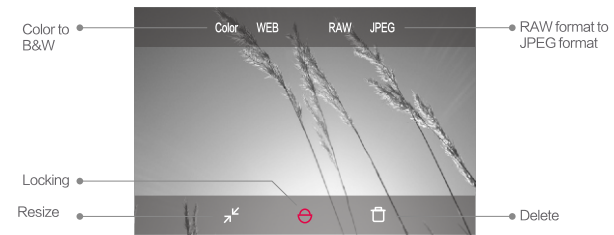

2. Information display/index display

Rotate control dial counter-clockwise to alternate between detailed info and index display.

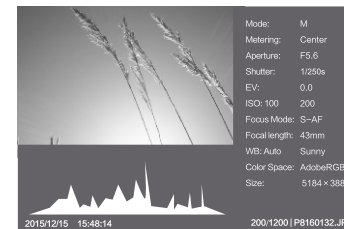



3. Enlarged view

- In playback mode, turn the control dial clockwise to enlarge the view.
- Double-click screen to enlarge the image 2x.
- The default enlarge setting can be configured to 2x–10x in advanced. Tap on Q button in Enlarged view to delete the picture.
- Zooming with gesture on the image is supported in single viewing mode/enlarged mode.
- In Enlarged viewing mode, single tap on the LCD Monitor to return to Single viewing mode.

4. Deleting images

- While in picture editing mode, you can tap on the Delete button at the bottom of the LCD Monitor to delete the picture.
- Tap "Delete" on the bottom of the LCD monitor to delete the picture.

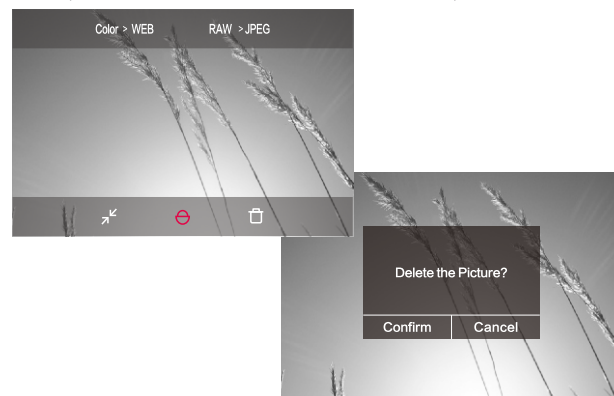

5. Watching videos

- 1) Press the ⏸ button to watch videos. You can press the playback button to pause, drag the slider to fast forward or backward, or drag the volume slider to adjust the volume.

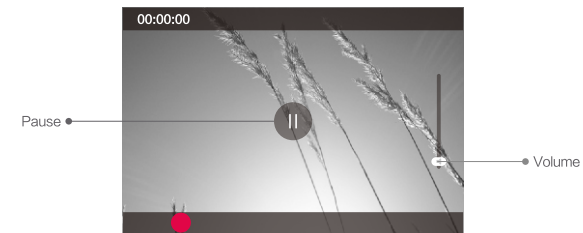

2) Deleting videos

- When playing a video, Long press (about 0.5s) on any blank area of the screen to display video edit menu, and tap on Delete icon to erase the video.
- Or Press the Q button to delete the video.

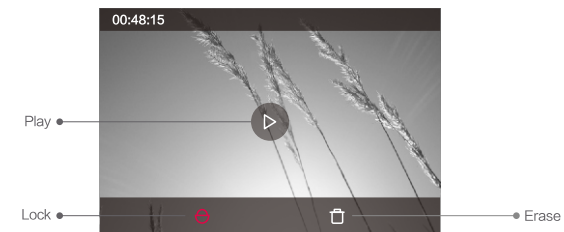

9. Connect YI Mirrorless App to YI-M1 Mirrorless Digital Camera



You can download the YI Mirrorless App from the App Store® or Google Play. You can also scan the QR code to download YI Mirrorless App. You can download photos, upload Master Guide templates to the camera, and update firmware through the App once it has been paired to your phone.

1. How to connect YI-M1 Mirrorless Digital Camera to YI Mirrorless App (Android), only necessary one time:

- A. Insert the micro SD card into the camera and power on;
- B. Enable the phone's Bluetooth and Wi-Fi, then open App to pair the camera Bluetooth to your phone for the first time;
- C. On the App connection page, follow the prompt to pair the camera Bluetooth;
- D. After the Bluetooth pairing is successful, follow the prompt to connect the camera Wi-Fi, once the connection is complete, you can view the camera album.

2. How to connect YI-M1 Mirrorless Digital Camera to YI Mirrorless App (iOS), only necessary one time:

- A. Insert the micro SD card into the camera and power on;
- B. Enable the phone's Bluetooth and Wi-Fi, then open App to pair the camera Bluetooth to your phone for the first time;
- C. On the App connection page, follow the prompt to pair the camera Bluetooth;
- D. After the Bluetooth pairing is successful, follow the prompt to connect the camera Wi-Fi. Select the camera Wi-Fi network (Wi-Fi network name: YI_M1_XXXXX) under system settings, then press and hold the password input box to select [Paste] and press [Join]. Wait for the Wi-Fi network to automatically connect. Return to the YI Mirrorless App, once the connection is complete, you can view the camera album.



CAUTION:

To avoid fire or shock hazards, do not disassemble the camera, expose it to water or high-humidity environment.

General precautions: Before you use the product, please read the instructions thoroughly and keep this well for future reference.

Cleaning—Always unplug this product from the wall outlet before cleaning. Use only a damp cloth for cleaning. Never use any type of liquid, aerosol cleaner or any type of organic solvent to clean this product.

Accessories—For your safety, and to avoid product damage, use only accessories recommended by YI.

Humidity—To avoid the product being damaged by high humidity, it is advised to place this product in de-humidifying storage. **Humidity**—To avoid the product damage due to high humidity, it is advised to place this product in dehumidifying storage.

Location—To avoid damage to the product, mount the product securely on a stable tripod, stand, or bracket. **Location**—To avoid product damage, mount the product securely on a stable tripod, stand, or bracket.

Power Source—Please only use the batteries indicated by the label on this product.

Foreign Objects—To avoid injuries, never insert any metal object into the product.

Heat—Never use or store this product near any heated source such as hair dryer, oven, heater or any type of equipments or appliances that generate heat, including power amplifiers.

10. Safety precautions

1. Handling the camera

- 1) Do not use the camera near flammable or explosive gases.
- 2) Do not use or store the camera in dusty or humid environments.
- 3) Do not point the flash and LED (including AF illuminator) to people (infants, children, etc.) at close range.
- 4) Always use and store the camera out of the reach of children and infants to prevent the following dangerous situations which could cause serious injury;
 - Accidentally entangled by the camera strap may cause suffocation;
 - Accidentally swallowing the battery, cards or other small parts;
 - Accidentally firing the flash into their own eyes or those of another child;
 - Accidentally point the flash to the eyes of other children.
- 5) Do not look at the sun or strong light through the camera.
- 6) Do not cover the flash with your hand.
- 7) Use SD/SDHC/SDXC memory cards only. Never use other types of cards.
If you accidentally insert another type of card into the camera, contact an authorized distributor or service center. Do not try to remove the card by force.
- 8) Do not remove the battery with the power on, it may cause fire or burning of your hands.
- 9) Do not operate camera with wet hands.
- 10) Do not leave the camera in extremely high-temperature environments. Doing so may cause parts to deteriorate and in some circumstances, cause the camera to catch fire.
- 11) Covering the camera (with a blanket for instance) may lead to overheating and cause fire.

11. Wireless functions

1. Frequency: 2.412–2.462 GHz

Equivalent isotropic radiated power: Antenna gain $< 10\text{dBi}$ $\leq 100\text{mW}$ or $\leq 20\text{dBm}$

Maximum power spectral density: Antenna gain $< 10\text{dBi}$ $\leq 10\text{dBm/MHz}$ (EIRP) Carrier frequency tolerance: 20ppm

Band emission power: (outside 2.412–2.462 GHz band) $\leq -80\text{dBm/Hz}$ (EIRP)spurious emission (radiation) power(Corresponding to a carrier other than ± 2.5 times the channel bandwidth) $\leq -36\text{dBm/100kHz}$ (30–1000MHz) $\leq -33\text{dBm/100kHz}$ (2.412–2.462 GHz) $\leq -40\text{dBm/1MHz}$ (other 1–12.75GHz)

2. Do not use external antennas or other transmitting antennas.

3. Please stop using the camera immediately if you notice that you are interfering with other legal radio communications. You should take measures to remove the interference before you use the camera again.

4. Please be advised that the radio waves coming from the camera may interfere with other industrial/ scientific/ medical equipments.

5. Please do not use the camera on an airplane or at the airport.

This device complies with Part 15 of the FCC Rules / Industry Canada licence-exempt RSS standard(s). Operation is subject to the following two conditions: (1) this device may not cause harmful interference, and (2) this device must accept any interference received, including interference that may cause undesired operation.

Le présent appareil est conforme aux CNR d'Industrie Canada applicables aux appareils radio exempts de licence. L'exploitation est autorisée aux deux conditions suivantes : (1) l'appareil ne doit pas produire de brouillage, et (2) l'utilisateur de l'appareil doit accepter tout brouillage radioélectrique subi, même si le brouillage est susceptible d'en compromettre le fonctionnement.

Changes or modifications not expressly approved by the party responsible for compliance could void the user's authority to operate the equipment.

This equipment has been tested and found to comply with the limits for a Class B digital device, pursuant to part 15 of the FCC Rules. These limits are designed to provide reasonable protection against harmful interference in a residential installation. This equipment generates uses and can radiate radio frequency energy and, if not installed and used in accordance with the instructions, may cause harmful interference to radio communications. However, there is no guarantee that interference will not occur in a particular installation. If this equipment does cause harmful interference to radio or television reception, which can be determined by turning the equipment off and on, the user is encouraged to try to correct the interference by one or more of the following measures:

- Reorient or relocate the receiving antenna.
- Increase the separation between the equipment and receiver.
- Connect the equipment into an outlet on a circuit different from that to which the receiver is connected.
- Consult the dealer or an experienced radio/TV technician for help.

Under Industry Canada regulations, this radio transmitter may only operate using an antenna of a type and maximum (or lesser) gain approved for the transmitter by Industry Canada. To reduce potential radio interference to other users, the antenna type and its gain should be so chosen that the equivalent isotropically radiated power (e.i.r.p.) is not more than that necessary for successful communication.

Conformément à la réglementation d'Industrie Canada, le présent émetteur radio peut fonctionner avec une antenne d'un type et d'un gain maximal (ou inférieur) approuvé pour l'émetteur par Industrie Canada. Dans le but de réduire les risques de brouillage radioélectrique d'intention des autres utilisateurs, il faut choisir le type d'antenne et son gain de sorte que la puissance isotrope rayonnée équivalente (p.i.r.e.) ne dépasse pas l'intensité nécessaire à l'établissement d'une communication satisfaisante.

MPE Requirements

To satisfy FCC / IC RF exposure requirements, a separation distance of 20 cm or more should be maintained between the antenna of this device and persons during device operation. To ensure compliance, operations at closer than this distance is not recommended.

Les antennes installées doivent être situées de façon à ce que la population ne puisse être exposée à une distance de moins de 20 cm. Installer les antennes de façon à ce que le personnel ne puisse approcher à 20 cm ou moins de la position centrale de l'antenne. La FCC des États-Unis stipule que cet appareil doit être en tout temps éloigné d'au moins 20 cm des personnes pendant son fonctionnement.